

VODOVODNO OKNO

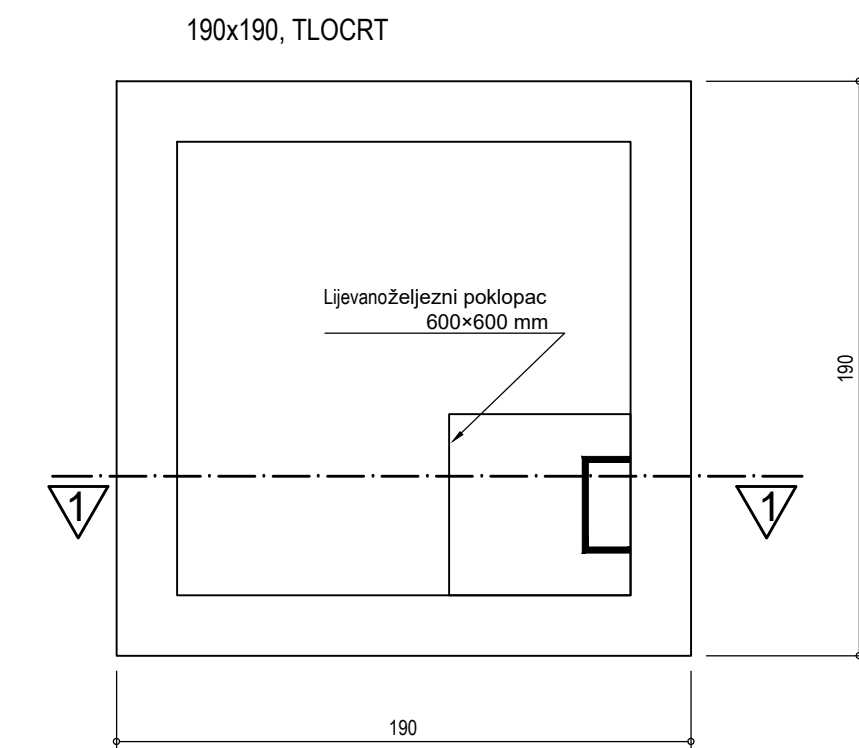

PRESJEK 1-1

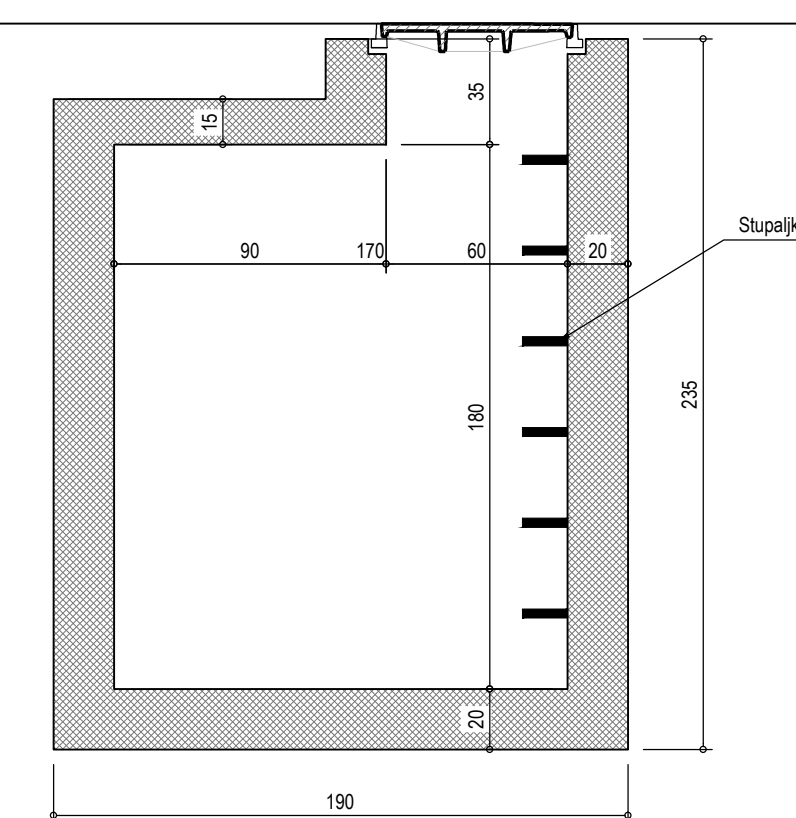

ROV VODOOPSKRBNOG CJEVOVODA

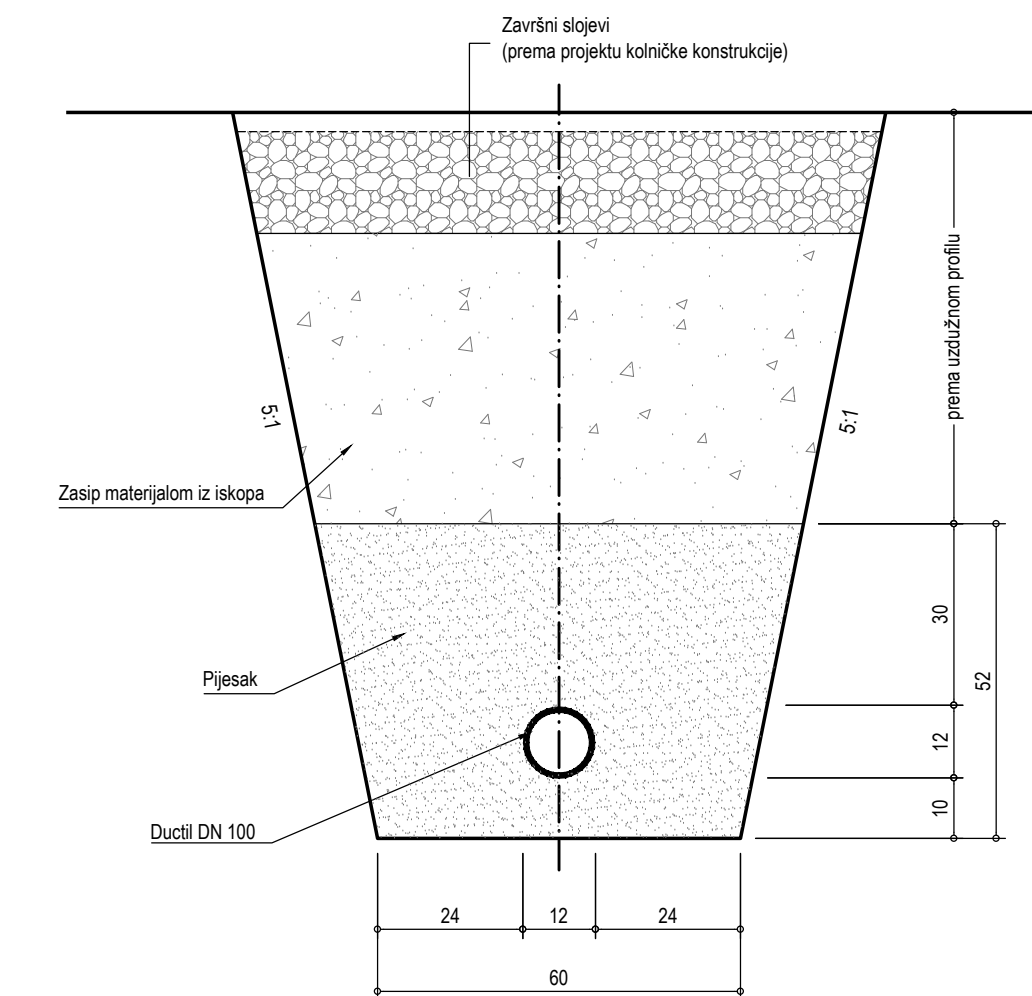

VO 1, (točka 1)

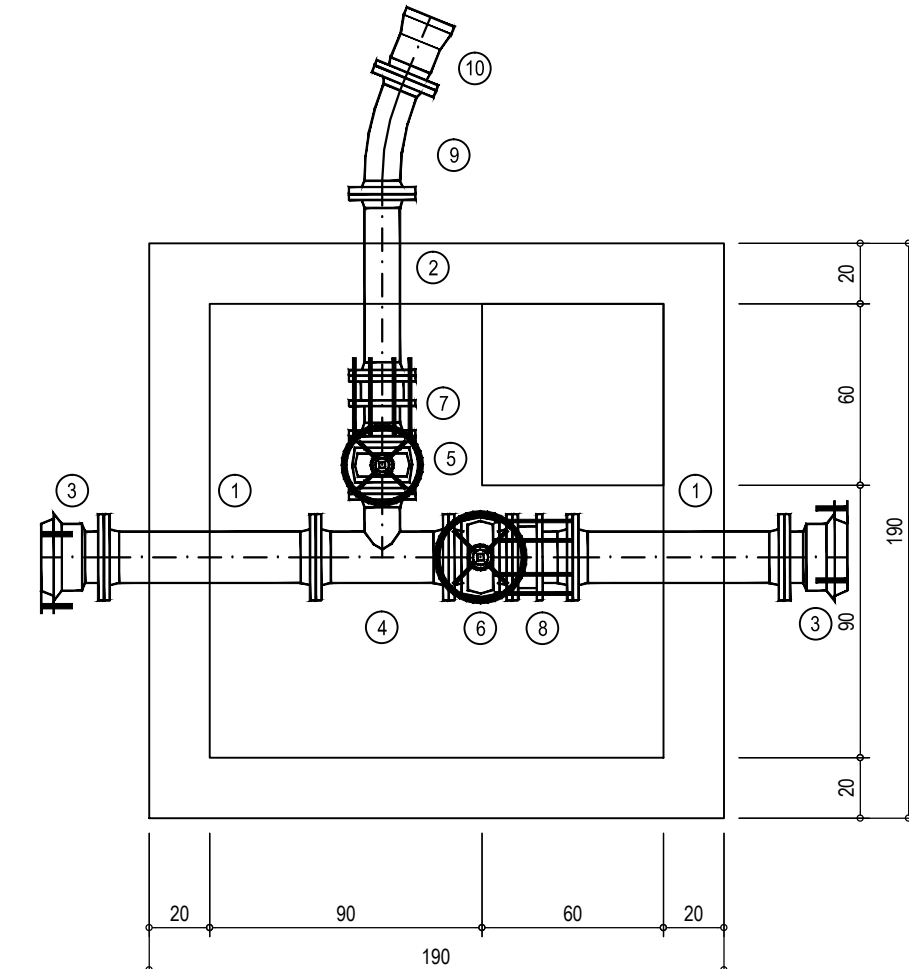

SPECIFIKACIJA

RED. BR.	OPIS KOMADA	OZN. Ili RF. MOD.	DN (mm)	PN (bar)	DULJINA Ili KUT	KOM.	TEZINA (kg/kom.)
1.	RAVNI KOMAD s pribnicama	FF	150	10	700	2	29.6
2.	RAVNI KOMAD s pribnicama	FF	100	10	600	1	17.4
3.	SPOJNICA WAGA MU tip 3050	MU/3050	150	16	208	2	15.3
4.	OTČJEPNI KOMAD s pribnicama	T	150	10	440	1	29.5
5.	EV-ZASUN kratki + kolo	V2-05	100	10	190	1	27.8
6.	EV-ZASUN kratki + kolo	V2-05	150	10	210	1	44.8
7.	MONTAŽNO-DEMONT. KOMAD MDKA kratki	MDKA	100	10	200	1	21.0
8.	MONTAŽNO-DEMONT. KOMAD MDKA kratki	MDKA	150	10	200	1	35.0
9.	LUK 22 1/2" s pribnicama	FFK22	100	10	22"1/2"	1	19.0
10.	SPOJNI KOMAD s pribnicama	EU	100	10	130	1	9.1

VO 2, (točka 10)

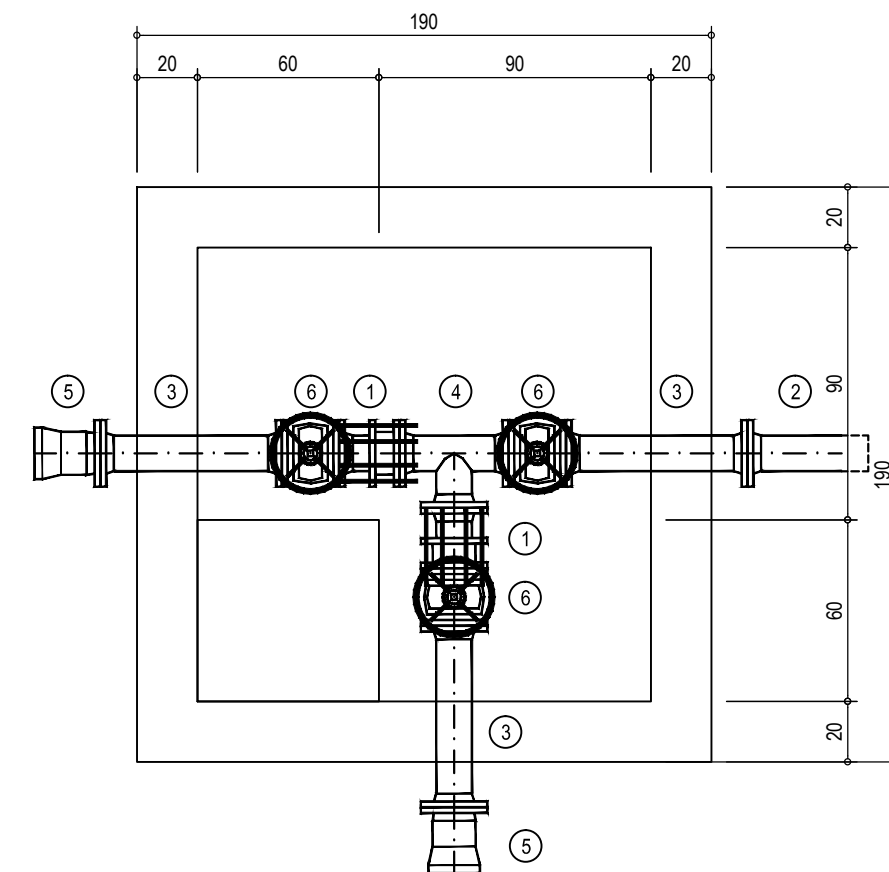

SPECIFIKACIJA

RED. BR.	OPIS KOMADA	OZN. Ili RF. MOD.	DN (mm)	PN (bar)	DULJINA Ili KUT	KOM.	TEZINA (kg/kom.)
1.	MONTAŽNO-DEMONT. KOMAD MDKA kratki	MDKA	100	10	200	2	21.0
2.	RAVNI KOMAD s pribnicama	F	100	10	400	1	9.7
3.	RAVNI KOMAD s pribnicama	FF	100	10	600	3	17.4
4.	OTČJEPNI KOMAD s pribnicama	T	100	10	360	1	19.4
5.	SPOJNI KOMAD s pribnicama	EU	100	10	130	2	9.1
6.	EV-ZASUN kratki + kolo	V2-05	100	10	190	3	27.8

PROTUPOŽARNI HIDRANT; NP 10

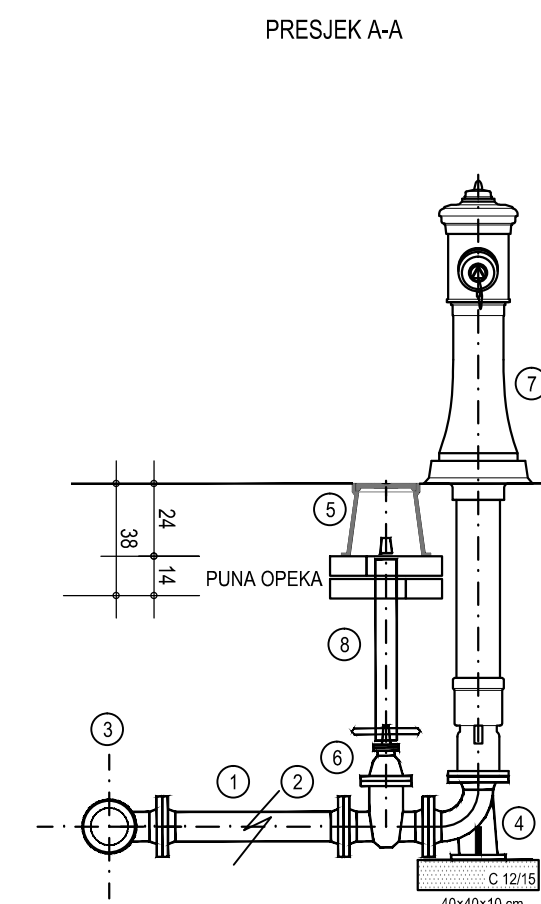

TLOCRT (HIDRANT 1)

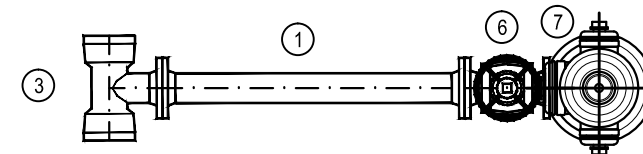

TLOCRT (HIDRANT 2)

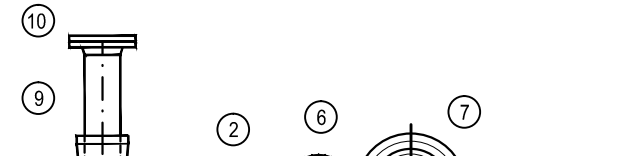

TLOCRT BUNARIČA OD OPEKE ZA ZASUN, M 1:10

DVA REDA PUNE OPEKE dim. 25x12x6.5 u cementnom mortu 1:4

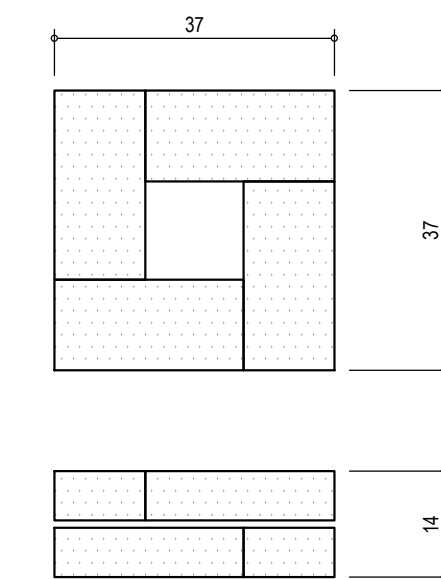

SPECIFIKACIJA

RED. BR.	OPIS KOMADA	OZN. Ili RF. MOD.	DN (mm)	PN (bar)	DULJINA Ili KUT	KOM.	TEZINA (kg/kom.)
1.	RAVNI KOMAD s pribnicama	FF	80	10	1000	1	20.1
2.	RAVNI KOMAD s pribnicama	FF	80	10	400	1	11.1
3.	OTČJEPNI KOMAD s pribnicama	MMA	80	10	170	2	12.8
4.	KUTNI KOMAD 90° s pribnicama	N	80	10	90°	2	13.0
5.	KRUŽNA ULIČNA KAPA	K-1016	230	125	2	8.0	
6.	OVALNI ZASUN + kolo red FS	3225	80	10	280	2	30.0
7.	NADZEMNI HIDRANT	V4-11	80	10	2150	2	90.0
8.	UGRADB. GARNITURA	V9-01	1000	125	2	5.0	
9.	RAVNI KOMAD s pribnicama	F	100	10	400	1	9.7
10.	ZAVRŠNI KOMAD	X	100	10		1	6.0

UKRUĆENJE HORIZONTALNIH KRIVINA

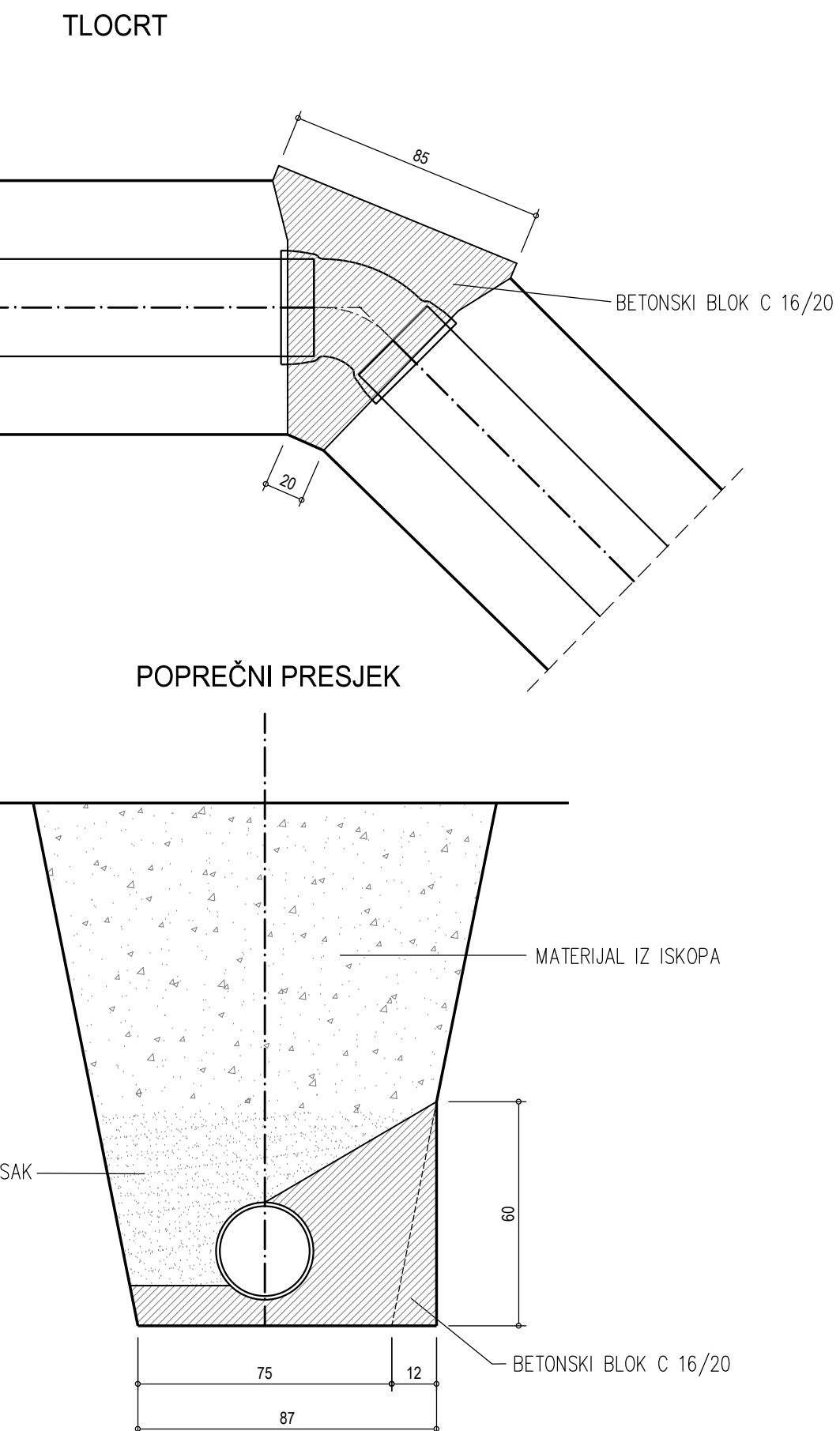

VODOOPSKRBNI CJEVOVOD

DETALJI IZVEDBE

MJ 1:25

**TRIVIUM**  
d.o.o. za projektiranje i nadzor

R. Botkovića 23, Split  
tel. 021 470 801, 470 449  
e-mail: trivium@st-kom.hr  
OIB 57426960741

Investitor:	OPĆINA SOLTVA, OIB: 38621571773 POČUVA.S. 21430, GRČH012	Z.O.P.
Gradevina:	IZGRADNJA NEKATEGORIZIRANE PROMETNICE U NASELJU MASLINICA NA OTOKU SOLTVA	MASLINICA-GP
Naziv projekta:	VODOOPSKRBA I KANALIZACIJA	T.D.
Strukovna odrednica:	GRAĐEVINSKI PROJEKT	38/18
Projektant:	Miroslav Jakovčević, dipl. ing. grad.	

Razina razrade:	GLAVNI PROJEKT	
Sadržaj:	VODOOPSKRBNI CJEVOVOD DETALJI IZVEDBE	MJ 1:25
Suradnik:	Sanja Vrdoljak, dipl. ing. grad.	
Mjesto i datum:	Split, ožujak 2018. god.	br. lista 7.